

CONSUMABLE SERIES

APPLICATIONS	• Ship • Commercial Truck & Trailer • Heavy Equipment • General Manufacturing & Fabrication
SYSTEM COMPONENTS	• Contact Tip • Nozzles • Diffusers / Tip Holders • Insulators
COMPATIBLE WITH	• BTB Series MIG Guns • S-Gun™ MIG Guns • Clean Air® Series • Dura-Flux™ Fixed Liner Series • FILTAIR™ Fume Extraction Series • Legacy Q-Gun™ Series
WIRE SIZES	• 0.023" to 3/32" (0.06 to 2.4 mm)

CENTERFIRE™ SERIES CONSUMABLES

Easy-to-use and high performing. Developed with the user's cost consideration in mind, Centerfire™ Series consumables provide better arc starts, less spatter and more consistent welds, while lasting up to three times longer than most brands.

CENTERFIRE™ HD CONSUMABLES



Designed for shipbuilding, trailer fabrication and other heavy manufacturing operations. These heavy-duty nozzles feature an easily removable and replaceable nozzle cone (the most frequently damaged part of the nozzle), thicker walls and a new, high temperature insulator.

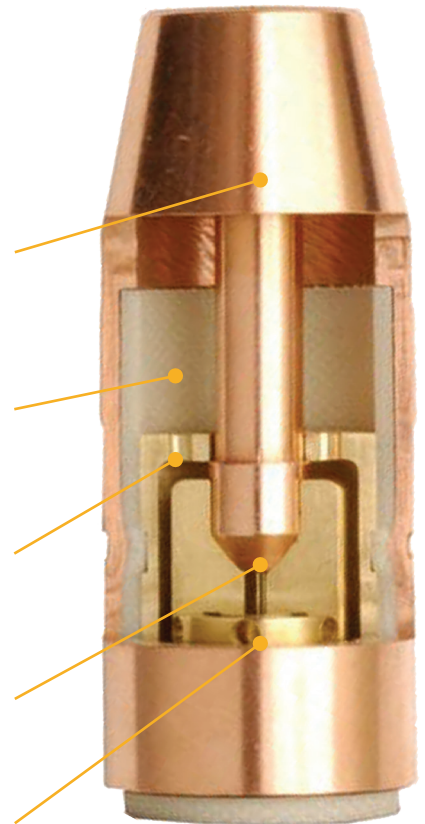

Threaded nozzle keeps contact tip centered for better weld placement and less spatter. Holds tips fixed at 1/4" or 1/8" recess, flush, or 1/8" stick out.

Composite insulator extends life and withstands heat abuse.

Centerfire™ nozzles have a built-in spatter shield that smooths and concentrates gas flow for less weld oxidation and contamination.

Centerfire™ contact tips have a tapered base to improve conductivity.

Diffuser mates securely with contact tip for better conductivity.



WARNING:
Cancer and Reproductive Harm
www.P65Warnings.ca.gov



TIPS ROTATE 360°
ROTATE TO CREATE NEW WEAR SURFACES AND EXTEND TIP LIFE



GOOD HEAT DISSIPATION
BETTER ARC STARTS, LESS SPATTER, MORE CONSISTENT WELDS



NO TOOLS REQUIRED
NO TOOLS NEEDED TO CHANGE NOZZLES AND CONTACT TIPS

CENTERFIRE™ SERIES

SMALL CENTERFIRE™ GAS DIFFUSERS AND NOZZLES

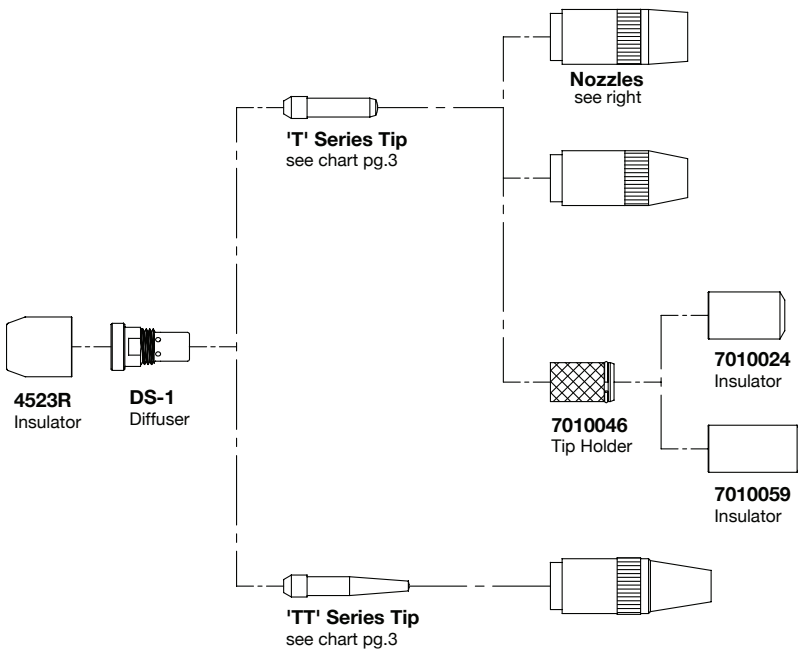

NOZZLES

- NS-5800C** 5/8" Bore, Flush, .875" O.D., Copper
- NS-5818C** 5/8" Bore, 1/8" Recess, .875" O.D., Copper
- NS-5800B** 5/8" Bore, Flush, .875" O.D., Brass
- NS-5818B** 5/8" Bore, 1/8" Recess, .875" O.D., Brass
- NS-1218C** 1/2" Bore, 1/8" Recess, .875" O.D., Copper
- NS-1200B** 1/2" Bore, Flush, .875" O.D., Brass
- NS-1218B** 1/2" Bore, 1/8" Recess, .875" O.D., Brass

NS-FLX Self-Shielded Conversion Kit
(Includes tip holder and both insulators)

- NST-3800B** 3/8" Bore, Flush, .875" O.D., Brass
- NST-3818B** 3/8" Bore, 1/8" Recess, .875" O.D., Brass
- NST-38XTB** 3/8" Bore, 1/8" Extension, .875" O.D., Brass

LARGE CENTERFIRE™ GAS DIFFUSERS AND NOZZLES

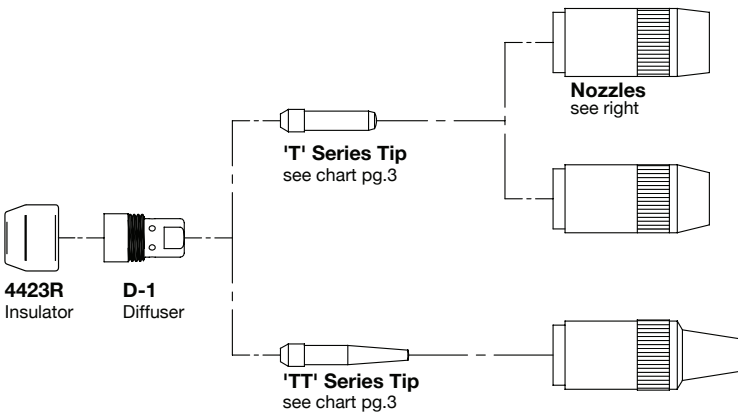

- N-3400C** 3/4" Bore, Flush, 1.063" O.D., Copper
- N-3418C** 3/4" Bore, 1/8" Recess, 1.063" O.D., Copper
- N-3414C** 3/4" Bore, 1/4" Recess, 1.063" O.D., Copper
- N-3418B** 3/4" Bore, 1/8" Recess, 1.063" O.D., Brass
- N-3414B** 3/4" Bore, 1/4" Recess, 1.063" O.D., Brass

- N-5800C** 5/8" Bore, Flush, 1.063" O.D., Copper
- N-5818C** 5/8" Bore, 1/8" Recess, 1.063" O.D., Copper
- N-5814C** 5/8" Bore, 1/4" Recess, 1.063" O.D., Copper
- N-5818B** 5/8" Bore, 1/8" Recess, 1.063" O.D., Brass
- N-5814B** 5/8" Bore, 1/4" Recess, 1.063" O.D., Brass

- NT-3800C** 3/8" Bore, Flush, 1.063" O.D., Copper

DIFFUSERS, NOZZLES AND CONTACT TIPS ARE AVAILABLE IN PACKAGES OF 10 AND INSULATORS ARE AVAILABLE IN PACKAGES OF 5

WATER-COOLED CENTERFIRE™ GAS DIFFUSERS AND NOZZLES

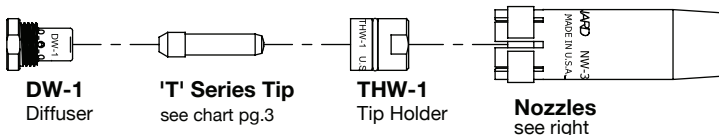

- NW-3418C** 3/4" Bore, 1/8" Recess, 1.000" O.D., Copper
- NW-3414C** 3/4" Bore, 1/4" Recess, 1.000" O.D., Copper

CENTERFIRE™ HD GAS DIFFUSERS AND NOZZLES

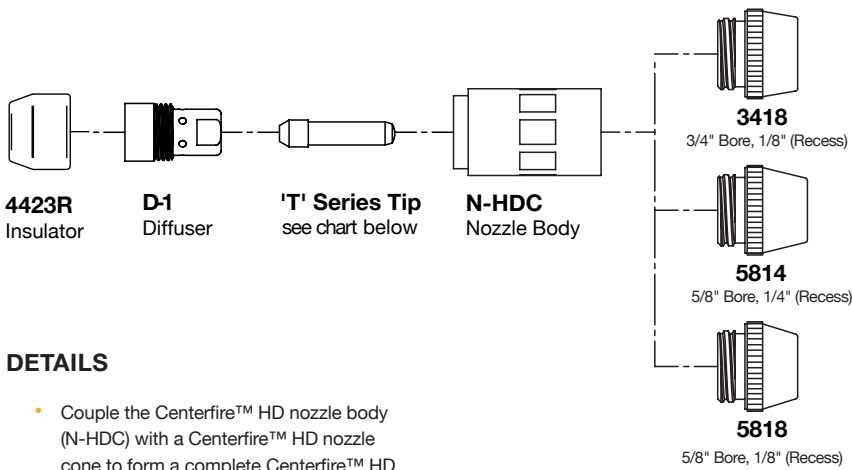

DETAILS

- Couple the Centerfire™ HD nozzle body (N-HDC) with a Centerfire™ HD nozzle cone to form a complete Centerfire™ HD nozzle.
- One nozzle body and one nozzle cone required, order separately.
- Use Centerfire™ HD nozzles with standard Centerfire™ 4423R insulator caps, D-1 gas diffusers and 'T' Series contact tips.

CENTERFIRE HD CONSUMABLE SERIES INSTALLATION

- Install insulator over neck
- Trim liner as per the directions below
- Torque diffuser onto neck to approx. 12ft-lbs
- Insert contact tip into diffuser
- Thread nozzle body onto diffuser / contact tip and tighten firmly by hand
- Thread nozzle cone onto nozzle body and tighten firmly by hand

DIFFUSERS, NOZZLE CONES AND BODIES AND CONTACT TIPS ARE AVAILABLE IN PACKAGES OF 10 AND INSULATORS ARE AVAILABLE IN PACKAGES OF 5

CENTERFIRE™ CONTACT TIPS

'T' SERIES CONTACT TIPS

(0.350" O.D.)

T-023	0.023"	(0.6 mm)
T-030	0.030"	(0.8 mm)
T-035	0.035"	(0.9 mm)
T-039	0.039"	(1.0 mm)
T-045	0.045"	(1.2 mm)
T-052	0.052"	(1.4 mm)
T-062	1/16"	(1.6 mm)
T-072	0.072"	(1.8 mm)
T-078	5/64"	(2.0 mm)
T-094	3/32"	(2.4 mm)

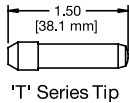

'T' Series Tip

'TT' SERIES CONTACT TIPS

(0.350" O.D.)

TT-030	0.030"	(0.8 mm)
TT-035	0.035"	(0.9 mm)
TT-039	0.039"	(1.0 mm)
TT-045	0.045"	(1.2 mm)
TT-052	0.052"	(1.4 mm)
TT-062	1/16"	(1.6 mm)

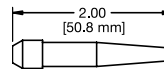

'TT' Series Tip

ALUMINUM SPECIFIC

CONTACT TIPS (0.350" O.D.)

T-035AL	0.035"	(0.9 mm)
T-047AL	3/64"	(1.2 mm)
T-062AL	1/16"	(1.6 mm)

AVAILABLE IN PACKAGES OF 10 CONTACTS TIPS

STANDARD INSTALLATION

- Install insulator over neck
- Trim liner to correct dimension below
- Torque diffuser onto neck to approx. 12ft-lbs
- Insert contact tip into diffuser
- Thread nozzle onto diffuser / contact tip and tighten firmly by hand

LINER TRIM GUIDELINES

To know the optimal length to trim your liner simply find your diffuser part number from the list below and trim to the corresponding length.

D-1	9/16" (14.3 mm)	D-1T	13/16" (20.6 mm)
DS-1	9/16" (14.3 mm)	D-1T-5	13/16" (20.6 mm)
DW-1	1/4" (6.4 mm)	DS-1T	5/8" (15.9 mm)

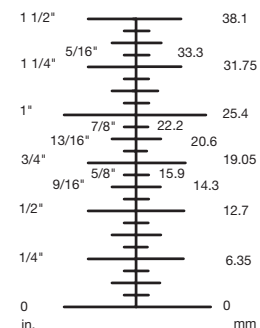

CENTERFIRE™ CONVERSION SERIES

Simplify parts management and improve performance by converting all of your MIG guns to Centerfire™ contact tips, nozzles and diffusers. Find your MIG gun make and model on the left, then follow the chart to the right for parts needed to upgrade.

CONVERSION INSTALLATION

- Install conversion adapter (if required)
- Install insulator cap over conversion adapter
- Proceed with standard or Centerfire™ HD Series installation

Gun Manufacturer	Gun Model	Desired Nozzle / Diffuser Style	Adapter	Insulator	Diffuser	Contact Tip	Nozzle
Bernard®	Q-Gun™, EZ Feed II, H, F	Small	Not Required	4323R	DS-1	Select from tips on page 3	Select from nozzles on pages 2-3 Note: use small nozzles with small diffusers and large nozzles with large diffusers
		Large	Not Required	10012	D-1		
Binzel®	ALPHA 2, ALPHA 2 Automatic	Small	Not Required	4323R	DS-1B2		
		Large	N/A	N/A	N/A		
	ALPHA 3, ALPHA 3 Automatic	Small	Not Required	4323R	DS-1B3		
		Large	Not Required	4323R	D-1B3		
	ALPHA 4, ALPHA 4 Automatic	Small	N/A	N/A	N/A		
		Large	Not Required	4323R	D-1B4		
Lincoln®	100L	Small	1380020	4323R	DS-1		
		Large	N/A	N/A	N/A		
	Magnum 250	Small	1380005	4323R	DS-1		
		Large	1380005	10012	D-1		
	Magnum 300, Magnum 400	Small	Not Required	4323R	DS-1T		
		Large	Not Required	4423R	D-1T		
	Magnum 500	Small	1380017	4323R	DS-1		
		Large	1380017	10012	D-1		
	Magnum Pro 300	Small	N/A	N/A	N/A		
		Large	Not Required	4323R	D-1LP3		
Miller®	XR Edge	Small	1380018	4323R	DS-1		
		Large	1380018	10012	D-1		
	XR30A, XR-W, Roughneck, Python	Small	Not Required	4323R	DS-1		
		Large	Not Required	10012	D-1		
Aluma-Pro™	Small	Not Required	4323R	DS-1AP			
	Large	Not Required	10012	D-1AP			
OXO™	APX	Small	Not Required	4323R	DS-1		
		Large	Not Required	10012	D-1		
Tregaskiss®	Former TOUGH GUN™ Semi-Automatic Series or the former Bernard T-Gun™	Small	Not Required	4323R	DS-1T		
		Large	Not Required	4423R	D-1T		
Tweco®	160 Mini Mig	Small	1380020	4323R	DS-1		
		Large	1380020	10012	D-1		
	No. 1	Small	1380019	4323R	DS-1		
		Large	1380019	10012	D-1		
	No. 2	Small	1380005	4323R	DS-1		
		Large	1380005	10012	D-1		
	No. 3, No. 4, Tuff-n-Lite, Supra® XT (HD Consumables)	Small	Not Required	4323R	DS-1T		
		Large	Not Required	4423R	D-1T		
	Spraymaster® 450	Small	Not Required	4323R (2 Required)	DS-1T		
		Large	Not Required	4423R	D-1T		
	No. 5	Small	N/A	N/A	N/A		
		Large	Not Required	4423R	D-1T-5		
	ELC 250, ELC 350, Spraymaster® 250, Spraymaster® 350	Small	1380012	4323R	DS-1		
		Large	1380012	10012	D-1		
	ELC 450, EL 450, EL 600, Supra® XT (EL Consumables)	Small	1380017	4323R	DS-1		
		Large	1380017	10012	D-1		

CENTERFIRE™ CONTACT TIPS, NOZZLES, AND DIFFUSERS ARE MANUFACTURED BY BERNARD. BERNARD®, MILLER®, TREGASKISS®, CENTERFIRE™, Q-GUN™ AND T-GUN™ ARE TRADEMARKS OF ILLINOIS TOOL WORKS, INC. OTHER BRANDS MENTIONED ARE FOR REFERENCE ONLY AND ARE THE REGISTERED TRADEMARKS OF THEIR RESPECTIVE COMPANIES. ILLINOIS TOOL WORKS, INC. IS NOT AFFILIATED WITH THESE OTHER COMPANIES. SUBJECT TO CHANGE – THE INFORMATION PRESENTED IN THIS SPEC SHEET IS ACCURATE TO THE BEST OF OUR KNOWLEDGE AT THE TIME OF PRINTING. PLEASE VISIT BERNARDTREGASKISS.COM FOR THE MOST UP-TO-DATE INFORMATION.

DISTRIBUTED BY:

©2024 Bernard®

